

# Reliable®

## Model F1FR56-300 QREC Series 300 psi (20,7 bar) Rated Quick Response Extended Coverage Spray

### Model F1FR56-300

#### Extended Coverage Sprinklers

#### Sprinkler Types

- Pendent
- Recessed Pendent F1/F2/FP
- Concealed Pendent

#### Approval Organizations

1. Listed by Underwriters Laboratories, Inc. and Certified for Canada (cULus)

#### UL Listing Category

Sprinklers, Automatic & Open  
Quick Response Sprinkler

#### UL Guide Number

VNIV

#### Product Description

Reliable Models F1FR56-300 QREC and F1FR56-300 QREC recessed pendent sprinklers are high pressure rated automatic sprinklers which can handle a maximum service pressure of 300 psi (20,7 bar).

The Reliable Model F1FR56-300 QREC Quick Response Extended Coverage Concealed Sprinkler is an attractive, low profile concealed sprinkler assembly. This sprinkler assembly utilizes a Model F1FR56-300 QREC pendent sprinkler in a Model CCP cup and push-on thread-off cover plate assembly. The cup is securely factory threaded on the sprinkler's inlet end. The assembly is shipped with a protective cap. The sprinkler and cup are easily installed into the sprinkler fitting using the Model RC1 Sprinkler Wrench. The cover plate assembly is attached to the sprinkler cup using a flexible tooth threaded engagement. The cover plate is attached to the skirt using 135°F (57°C) ordinary temperature classification solder.

When the ceiling temperature rises, the solder holding the cover plate melts, allowing the release of this part and thus exposing the Model F1FR56-300 QREC sprinkler inside to the rising ambient temperature.

These Models are quick response sprinklers which utilize a 3.0mm frangible glass bulb. These sprinklers have demonstrated response times in laboratory tests which are five times faster than standard response sprinklers. This quick response enables Model F1FR56-300 QREC sprinklers to apply water to a fire much faster than standard sprinklers of the same temperature rating.



QREC Pendent



Recessed QREC  
Pendent F1/F2



Concealed QREC Pendent



Recessed QREC  
Pendent FP

The glass bulb contains an accurately controlled amount of special fluid hermetically sealed inside a precisely manufactured glass capsule. This glass bulb is specially constructed to provide fast thermal response.

At normal temperatures, the glass bulb contains fluid in both the liquid and vapor phases. The vapor phase can be seen as a small bubble. As heat is applied, the liquid expands, forcing the bubble smaller and smaller as the liquid pressure increases. Continued heating forces the liquid to push out against the bulb, causing the glass to shatter, operating the waterway and allowing the deflector to distribute the discharging water.

The temperature rating of the sprinkler is identified by the color of the glass bulb.

#### Application

The most common applications for Model F1FR56-300 QREC Sprinklers will be in fire protection systems for high rise buildings where a quick response rating is required and the pressure entering the sprinkler system is in excess of 175 psi (12 bar). The use of these sprinklers will provide the opportunity to reduce or eliminate the need for pressure reducing valves.

# Model F1FR56-300 Quick Response Extended Coverage Pendant Sprinkler

**Deflector:** QREC

**Installation Wrench:** Model D Sprinkler Wrench

**Approval Type:** Quick Response Extended Coverage - Light Hazard Occupancy

## Installation Data:

Nominal Orifice	Thread Size	"K" Factor		Sprinkler Length	Temperature Rating		Sprinkler Identification Numbers (SIN)
		US	Metric		°F	°C	
1/2" (15mm)	1/2" NPT (R1/2)	5.6	80	2.25" (57mm)	135 155	57 68	RA3045



QREC Pendant

**Table 1**

Coverage Area					
Flow Rate		Pressure K=5.6 (80)		Max. Coverage Area Width x Length	
gpm	L/min	psi	bar	ft. x ft.	m x m
26	98.4	21.6	1,5	16 x 16	4.9 x 4.9
33	124.9	34.7	2,4	18 x 18	5.5 x 5.5
40	151.5	51.0	3,5	20 x 20	6.0 x 6.0 <sup>(1)</sup>

<sup>(1)</sup> 135°F (57°C) only.

# Model F1FR56-300 Quick Response Extended Coverage Recessed Pendant Sprinkler

**Deflector:** QREC

**Installation Wrench:** Model GFR2 Sprinkler Wrench

**Approval Type:** Quick Response Extended Coverage - Light Hazard Occupancy

## Installation Data<sup>(1)</sup>:

Nominal Orifice	Thread Size	"K" Factor		Sprinkler Length	Temperature Rating		Sprinkler Identification Numbers (SIN)
		US	Metric		°F	°C	
1/2" (15mm)	1/2" NPT (R1/2)	5.6	80	2.25" (57mm)	135 155	57 68	R3045

<sup>(1)</sup> For Coverage Area refer to Table 1.

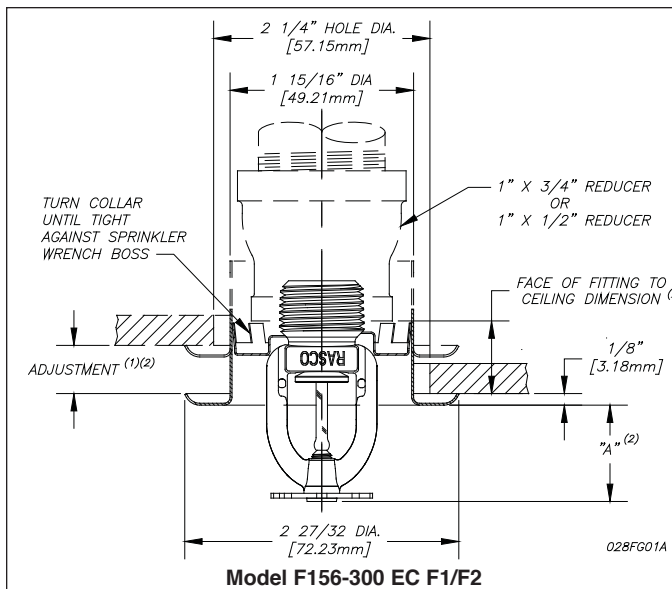

Fig. 1

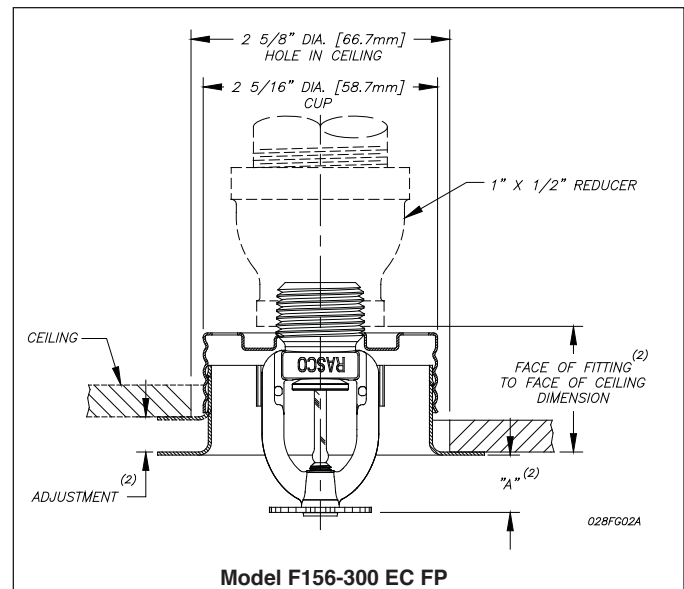

Fig. 2

<sup>(1)</sup> When installed directly into a tee, the escutcheon adjustment will be reduced.

<sup>(2)</sup> Refer to escutcheon data table for dimensions.

# Model F1FR56-300 Quick Response Extended Coverage Concealed Pendent Sprinkler

**Installation Wrench:** Model RC1 Sprinkler Wrench

**Approval Type:** Quick Response Extended Coverage - Light Hazard Occupancy

## Technical Data:

Nominal Orifice	Thread Size	"K" Factor		Sprinkler Identification Number (SIN)
		US	Metric	
1/2" (15mm)	1/2" (R1/2)	5.6	80	RA3045

Thread Size	Model	Temp. Rating		Max. Ambient Temp.	Bulb Color
		Sprinkler	Cover		
1/2" NPT (R1/2)	F1FR-300	135°F	135°F	100°F	Orange
	QREC	57°C	57°C	38°C	
1/2" NPT (R1/2)	F1FR-300	155°F	135°C	100°F	Red
	QREC	68°C	57°C	38°C	

Flow Rate gpm (L/m)	Coverage Area	
	Pressure psi (bar)	Max. Coverage Area Width x Length ft. x ft. (m x m)
21.2 (80.3)	14.2 (0,98)	14 x 14 (4.3 x 4.3)
26 (98.4)	21.6 (1,5)	16 x 16 (4.9 x 4.9)
33 (124.9)	34.7 (2,4)	18 x 18 (5.5 x 5.5)
40 (151.5)	51.0 (3,5)	20 x 20 <sup>(1)</sup> (6.0 x 6.0) <sup>(1)</sup>

<sup>(1)</sup> 135°F (57°C) Only

## Installation Aid:

A protective cap is included for use during installation.

## Installation

Quick response sprinklers are intended for installation as specified in NFPA 13. Quick response sprinklers and standard response sprinklers should not be intermixed.

The Model F1FR56-300 QREC Pendent and Recessed Sprinklers are to be installed as illustrated. The Model F1, F2, and FP escutcheons illustrated are the only recessed escutcheons to be used with the these sprinklers. The use of any other recessed escutcheon will void all approvals and negate all warranties.

When installing Model F1FR56-300 QREC Pendent Sprinklers, use the Model D Sprinkler Wrench. When installing F1FR56-300 QREC Recessed Pendent Sprinkler, use the Model GFR2 Sprinkler Wrench. Any other type of wrench may damage these sprinklers.

Model F1FR56-300 QREC Concealed Sprinklers use 135°F (57°C) or 155°F (68°C) Model F1FR56-300 QREC Pendent Sprinklers with a threaded Model CCP cup which is factory attached to the sprinkler. The assembly is completed by the installation of the attractive, low profile, 135°F (57°C) rated cover plate assembly. The cover plate and sprinkler cup are joined using a flexible tooth threaded engagement. A choice of two cover plate assemblies provides either 1/2" (13mm) or 5/16" (8mm) of cover adjustment.

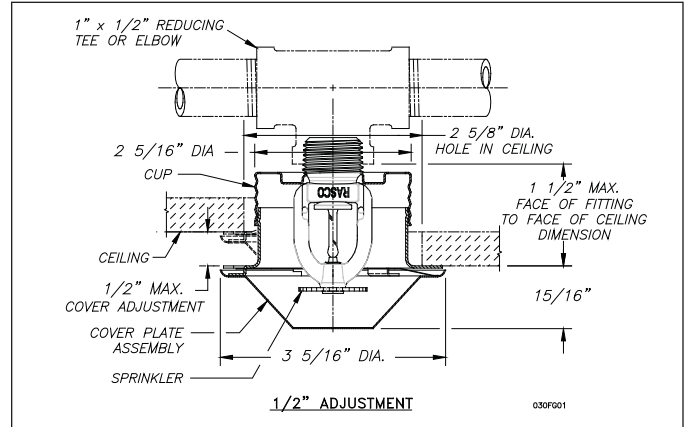

Fig. 3

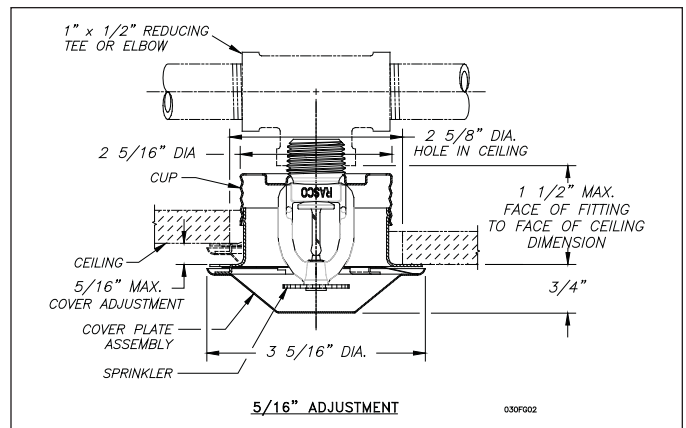

Fig. 4

Do not install these sprinklers in ceilings which have positive pressure in the space above.

After a 2<sup>5</sup>/<sub>8</sub>" (67mm) inch diameter hole is cut in the ceiling, the sprinkler is easily installed with the Model RC1 Wrench. When installing a sprinkler, the protective cap is removed and the wrench is positioned into the sprinkler/cup assembly until the two wrench faces engage the wrenching flats on the Model F1FR56 QREC Sprinkler. The sprinkler is then tightened into the pipe fitting. When inserting or removing the wrench from the sprinkler/cup assembly, care should be taken to prevent damage to the sprinkler. DO NOT WRENCH ON ANY OTHER PART OF THE SPRINKLER. The cover plate assembly is then pressed into the cup. Final adjustment is made by turning the cover plate until the skirt flange makes full contact with the ceiling surface. Cover plate removal requires turning in the counter clockwise direction.

After installation, inspect all sprinklers to ensure that there is a gap between the cover plate and ceiling and that the four cup slots are open and free from any air flow impediment to the space above.

Concealed cover plate/cup assemblies are listed only for use with specific sprinklers. The use of any other concealed cover plate/cup assembly with the Model F1FR56-300 QREC Pendent Sprinkler or the use of the Model CCP concealed cover plate assembly on any sprinkler with which it is not specifically listed may prevent good fire protection and will void all guarantees, warranties, listings and approvals.

Glass bulb sprinklers have orange bulb protectors to minimize bulb damage during shipping, handling and installation. REMOVE THIS PROTECTION AT THE TIME THE SPRINKLER SYSTEM IS PLACED IN SERVICE FOR FIRE PROTECTION. Removal of the protectors before this time may leave the bulb vulnerable to damage. RASCO wrenches are designed to install sprinklers when covers are in place. REMOVE PROTECTORS BY UNDOING THE CLASP BY HAND. DO NOT USE TOOLS TO REMOVE THE PROTECTORS.

### Maintenance

Model F1FR56-300 QREC Sprinklers should be inspected quarterly and the sprinkler system maintained in accordance with NFPA 25. Do not clean sprinklers with soap and water, ammonia or any other cleaning fluids. Remove dust by using a soft brush or gentle vacuuming. Remove any sprinkler that has been painted (other than factory applied) or damaged in any way. A stock of spare sprinklers should be maintained to allow quick replacement of damaged or operated sprinklers. Prior to installation, sprinklers should be maintained in the original cartons and packaging until used to minimize the potential for damage to sprinklers that would cause improper operation or non-operation.

### Escutcheon Data:

Escutcheon Model	Adjustment	"A" Dimension	Face of Fitting to Ceiling or Wall Dimension
F1	Max Recess	1 1/2" (38.1mm)	3/16" - 15/16"
	Min Recess	3/4" (19.1mm)	(5mm - 24mm)
F2	Max Recess	1 1/2" (38.1mm)	3/16" - 1 1/16"
	Min Recess	1" (24mm)	(5mm - 17mm)
FP Push-on/ Thread-off	Max Recessed	7/16" (11mm)	1 1/2" (38.1mm)
	Min Recessed	15/16" (24mm)	1" (25.4mm)

### Maximum Working Pressure

300 psi (20.7 bar)

100% Factory tested hydrostatically to 600 psi (41.4 bar)

### Finishes <sup>(1)</sup>

Standard Finishes	
Sprinkler	Escutcheon
Bronze	Brass
Chrome Plated	Chrome Plated
White Polyester Coated	White Painted
Special Application Finishes	
Sprinkler	Escutcheon
Bright Brass	Bright Brass
Black Plated	Black Plating
Black Paint	Black Paint
Off White	Off White
Satin Chrome	Satin Chrome

### Cover Plate Finishes<sup>(1)</sup>

Standard Finishes
Chrome
White
Special Application Finishes
Bright Brass
Black Plating
Black Paint
Off White

<sup>(1)</sup> Other colors and finishes are available on special order. Consult factory for details. Coverplate custom paint is semi-gloss, unless specified otherwise.

**Note:** Paint or any other coating applied over the factory finish will void approvals and warranties.

### Ordering Information

Specify:

1. Sprinkler Model
2. Sprinkler Type
3. Orifice Size
4. Deflector Type
5. Temperature Rating
6. Sprinkler Finish
7. Escutcheon Type
8. Escutcheon Finish (where applicable)
9. Cover Plate Model
10. Cover Plate Thread Size
11. Cover Plate Temperature Rating
12. Cover Plate Adjustment
13. Cover Plate Finish

**Note:** When F1FR56-300 QREC Recessed sprinklers are ordered, the sprinklers, escutcheons and coverplates are packaged separately.

The equipment presented in this bulletin is to be installed in accordance with the latest published Standards of the National Fire Protection Association, Factory Mutual Research Corporation, or other similar organizations and also with the provisions of governmental codes or ordinances whenever applicable. Products manufactured and distributed by Reliable have been protecting life and property for over 80 years, and are installed and serviced by the most highly qualified and reputable sprinkler contractors located throughout the United States, Canada and foreign countries.

Manufactured by



The Reliable Automatic Sprinkler Co., Inc.  
 (800) 431-1588 Sales Offices  
 (800) 848-6051 Sales Fax  
 (914) 829-2042 Corporate Offices  
 www.reliablesprinkler.com Internet Address



Revision lines indicate updated or new data.  
 EG. Printed in U.S.A. 01/12 P/N 9999970390